

IC1B	P5	EDOUT00P
EDIN00P	U5	EDOUT00P
EDIN01P	U6	EDOUT01P
EDIN02P	U7	EDOUT02P
EDIN03P	U8	EDOUT03P
EDIN04P	U9	EDOUT04P
EDIN05P	U10	EDOUT05P
EDIN06P	U11	EDOUT06P
EDIN07P	U12	EDOUT07P
EDIN08P	U13	EDOUT08P
EDIN09P	U14	EDOUT09P
EDIN10P	U15	EDOUT10P
EDIN11P	U16	EDOUT11P
EDIN12P	U17	EDOUT12P
EDIN13P	U18	EDOUT13P
EDIN14P	U19	EDOUT14P
EDIN15P	U20	EDOUT15P
EDIN16P	U21	EDOUT16P
EDIN17P	U22	EDOUT17P
EDIN18P	U23	EDOUT18P
EDIN19P	U24	EDOUT19P
EDIN20P	U25	EDOUT20P
EDIN21P	U26	EDOUT21P
EDIN22P	U27	EDOUT22P
EDIN23P	U28	EDOUT23P
EDIN24P	U29	EDOUT24P
EDIN25P	U30	EDOUT25P
EDIN26P	U31	EDOUT26P
EDIN27P	U32	EDOUT27P
EDIN28P	U33	EDOUT28P
EDIN29P	U34	EDOUT29P
EDIN30P	U35	EDOUT30P
EDIN31P	U36	EDOUT31P
EDIN32P	U37	EDOUT32P
EDIN33P	U38	EDOUT33P
EDIN34P	U39	EDOUT34P
EDIN35P	U40	EDOUT35P
EDIN36P	U41	EDOUT36P
EDIN37P	U42	EDOUT37P
EDIN38P	U43	EDOUT38P
EDIN39P	U44	EDOUT39P
EDIN40P	U45	EDOUT40P
EDIN41P	U46	EDOUT41P
EDIN42P	U47	EDOUT42P
EDIN43P	U48	EDOUT43P
EDIN44P	U49	EDOUT44P
EDIN45P	U50	EDOUT45P
EDIN46P	U51	EDOUT46P
EDIN47P	U52	EDOUT47P
EDIN48P	U53	EDOUT48P
EDIN49P	U54	EDOUT49P
EDIN50P	U55	EDOUT50P
EDIN51P	U56	EDOUT51P
EDIN52P	U57	EDOUT52P
EDIN53P	U58	EDOUT53P
EDIN54P	U59	EDOUT54P
EDIN55P	U60	EDOUT55P
EDIN56P	U61	EDOUT56P
EDIN57P	U62	EDOUT57P
EDIN58P	U63	EDOUT58P
EDIN59P	U64	EDOUT59P
EDIN60P	U65	EDOUT60P
EDIN61P	U66	EDOUT61P
EDIN62P	U67	EDOUT62P
EDIN63P	U68	EDOUT63P
EDIN64P	U69	EDOUT64P
EDIN65P	U70	EDOUT65P
EDIN66P	U71	EDOUT66P
EDIN67P	U72	EDOUT67P
EDIN68P	U73	EDOUT68P
EDIN69P	U74	EDOUT69P
EDIN70P	U75	EDOUT70P

IC1C	T4	ECLK0P
ECLK0P	U4	ECLK0P
ECLK1P	U5	ECLK1P
ECLK2P	U6	ECLK2P
ECLK3P	U7	ECLK3P
ECLK4P	U8	ECLK4P
ECLK5P	U9	ECLK5P
ECLK6P	U10	ECLK6P
ECLK7P	U11	ECLK7P
ECLK8P	U12	ECLK8P
ECLK9P	U13	ECLK9P
ECLK10P	U14	ECLK10P
ECLK11P	U15	ECLK11P
ECLK12P	U16	ECLK12P
ECLK13P	U17	ECLK13P
ECLK14P	U18	ECLK14P
ECLK15P	U19	ECLK15P
ECLK16P	U20	ECLK16P
ECLK17P	U21	ECLK17P
ECLK18P	U22	ECLK18P
ECLK19P	U23	ECLK19P
ECLK20P	U24	ECLK20P
ECLK21P	U25	ECLK21P
ECLK22P	U26	ECLK22P
ECLK23P	U27	ECLK23P
ECLK24P	U28	ECLK24P
ECLK25P	U29	ECLK25P
ECLK26P	U30	ECLK26P
ECLK27P	U31	ECLK27P
ECLK28P	U32	ECLK28P
ECLK29P	U33	ECLK29P
ECLK30P	U34	ECLK30P
ECLK31P	U35	ECLK31P
ECLK32P	U36	ECLK32P
ECLK33P	U37	ECLK33P
ECLK34P	U38	ECLK34P
ECLK35P	U39	ECLK35P
ECLK36P	U40	ECLK36P
ECLK37P	U41	ECLK37P
ECLK38P	U42	ECLK38P
ECLK39P	U43	ECLK39P
ECLK40P	U44	ECLK40P
ECLK41P	U45	ECLK41P
ECLK42P	U46	ECLK42P
ECLK43P	U47	ECLK43P
ECLK44P	U48	ECLK44P
ECLK45P	U49	ECLK45P
ECLK46P	U50	ECLK46P
ECLK47P	U51	ECLK47P
ECLK48P	U52	ECLK48P
ECLK49P	U53	ECLK49P
ECLK50P	U54	ECLK50P
ECLK51P	U55	ECLK51P
ECLK52P	U56	ECLK52P
ECLK53P	U57	ECLK53P
ECLK54P	U58	ECLK54P
ECLK55P	U59	ECLK55P
ECLK56P	U60	ECLK56P
ECLK57P	U61	ECLK57P
ECLK58P	U62	ECLK58P
ECLK59P	U63	ECLK59P
ECLK60P	U64	ECLK60P
ECLK61P	U65	ECLK61P
ECLK62P	U66	ECLK62P
ECLK63P	U67	ECLK63P
ECLK64P	U68	ECLK64P
ECLK65P	U69	ECLK65P
ECLK66P	U70	ECLK66P
ECLK67P	U71	ECLK67P
ECLK68P	U72	ECLK68P
ECLK69P	U73	ECLK69P
ECLK70P	U74	ECLK70P

IC1B	T5	EDOUT00P
EDOUT00P	R5	EDOUT00P
EDOUT01P	R6	EDOUT01P
EDOUT02P	R7	EDOUT02P
EDOUT03P	R8	EDOUT03P
EDOUT04P	R9	EDOUT04P
EDOUT05P	R10	EDOUT05P
EDOUT06P	R11	EDOUT06P
EDOUT07P	R12	EDOUT07P
EDOUT08P	R13	EDOUT08P
EDOUT09P	R14	EDOUT09P
EDOUT10P	R15	EDOUT10P
EDOUT11P	R16	EDOUT11P
EDOUT12P	R17	EDOUT12P
EDOUT13P	R18	EDOUT13P
EDOUT14P	R19	EDOUT14P
EDOUT15P	R20	EDOUT15P
EDOUT16P	R21	EDOUT16P
EDOUT17P	R22	EDOUT17P
EDOUT18P	R23	EDOUT18P
EDOUT19P	R24	EDOUT19P
EDOUT20P	R25	EDOUT20P
EDOUT21P	R26	EDOUT21P
EDOUT22P	R27	EDOUT22P
EDOUT23P	R28	EDOUT23P
EDOUT24P	R29	EDOUT24P
EDOUT25P	R30	EDOUT25P
EDOUT26P	R31	EDOUT26P
EDOUT27P	R32	EDOUT27P
EDOUT28P	R33	EDOUT28P
EDOUT29P	R34	EDOUT29P
EDOUT30P	R35	EDOUT30P
EDOUT31P	R36	EDOUT31P
EDOUT32P	R37	EDOUT32P
EDOUT33P	R38	EDOUT33P
EDOUT34P	R39	EDOUT34P
EDOUT35P	R40	EDOUT35P
EDOUT36P	R41	EDOUT36P
EDOUT37P	R42	EDOUT37P
EDOUT38P	R43	EDOUT38P
EDOUT39P	R44	EDOUT39P
EDOUT40P	R45	EDOUT40P
EDOUT41P	R46	EDOUT41P
EDOUT42P	R47	EDOUT42P
EDOUT43P	R48	EDOUT43P
EDOUT44P	R49	EDOUT44P
EDOUT45P	R50	EDOUT45P
EDOUT46P	R51	EDOUT46P
EDOUT47P	R52	EDOUT47P
EDOUT48P	R53	EDOUT48P
EDOUT49P	R54	EDOUT49P
EDOUT50P	R55	EDOUT50P
EDOUT51P	R56	EDOUT51P
EDOUT52P	R57	EDOUT52P
EDOUT53P	R58	EDOUT53P
EDOUT54P	R59	EDOUT54P
EDOUT55P	R60	EDOUT55P
EDOUT56P	R61	EDOUT56P
EDOUT57P	R62	EDOUT57P
EDOUT58P	R63	EDOUT58P
EDOUT59P	R64	EDOUT59P
EDOUT60P	R65	EDOUT60P
EDOUT61P	R66	EDOUT61P
EDOUT62P	R67	EDOUT62P
EDOUT63P	R68	EDOUT63P
EDOUT64P	R69	EDOUT64P
EDOUT65P	R70	EDOUT65P
EDOUT66P	R71	EDOUT66P
EDOUT67P	R72	EDOUT67P
EDOUT68P	R73	EDOUT68P
EDOUT69P	R74	EDOUT69P
EDOUT70P	R75	EDOUT70P

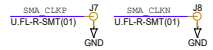
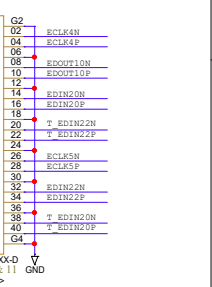
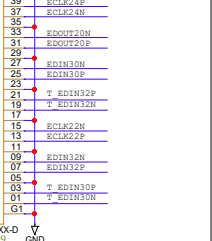
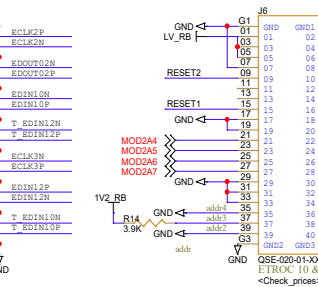
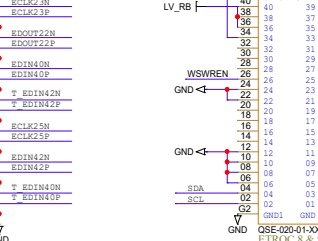
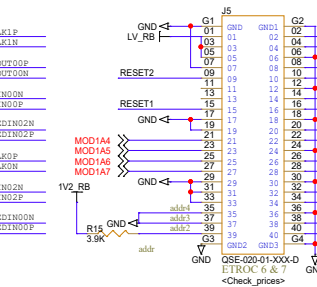
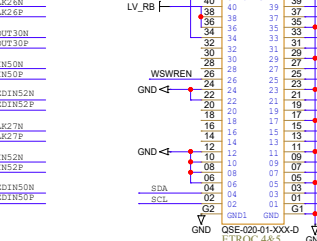
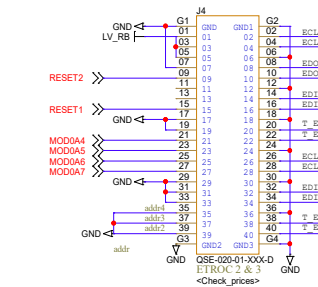
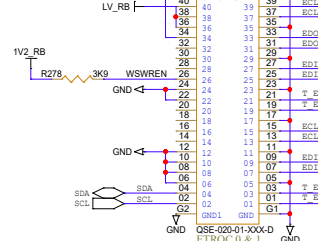

- TP9 — 2V5RX
- 2V5RX
- TP10 — 2V5TX
- 2V5TX
- TP5 — LV\_RB
- LV\_RB
- TP6 — 1V2\_RB
- 1V2\_RB

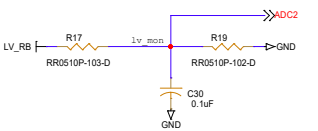

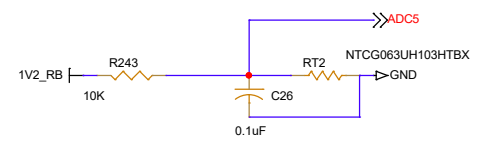
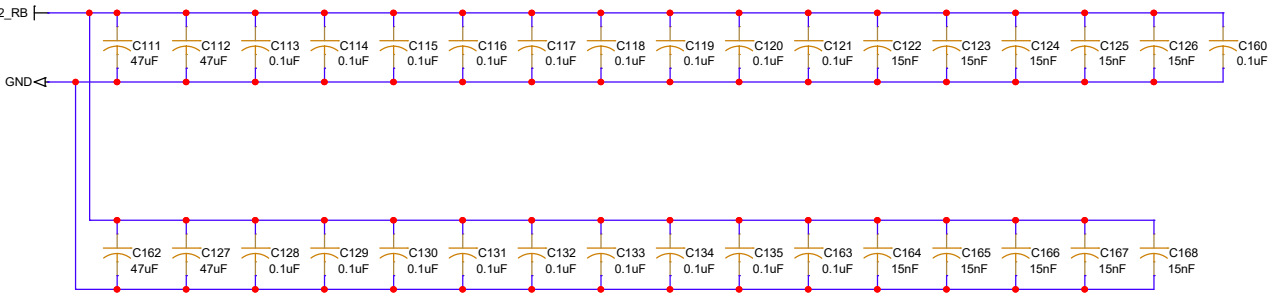
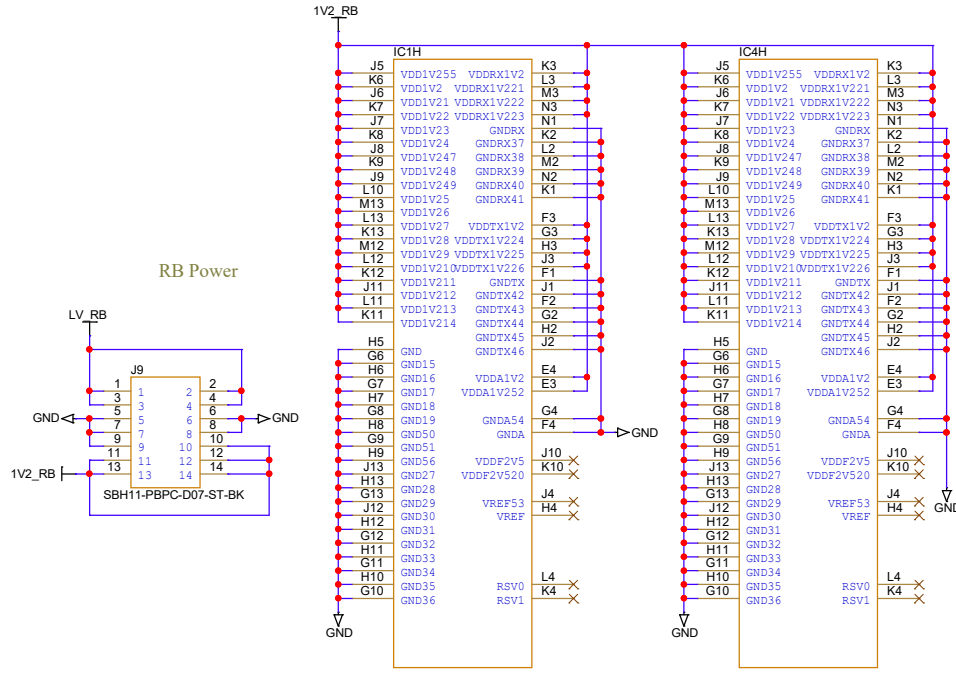

BU EDF		Converted from A. Peck's Altium design GB7-SCA replaced with MUX64	
<b>Title</b>			
<b>ETL READOUT BOARD RB3 (MUX64 ASIC)</b>			
<b>Size</b>	<b>Document Number</b>		<b>Rev</b>
B	<Doc>		2.0
<b>Date:</b>	Monday, February 28, 2024	<b>Sheet</b>	3 of 5

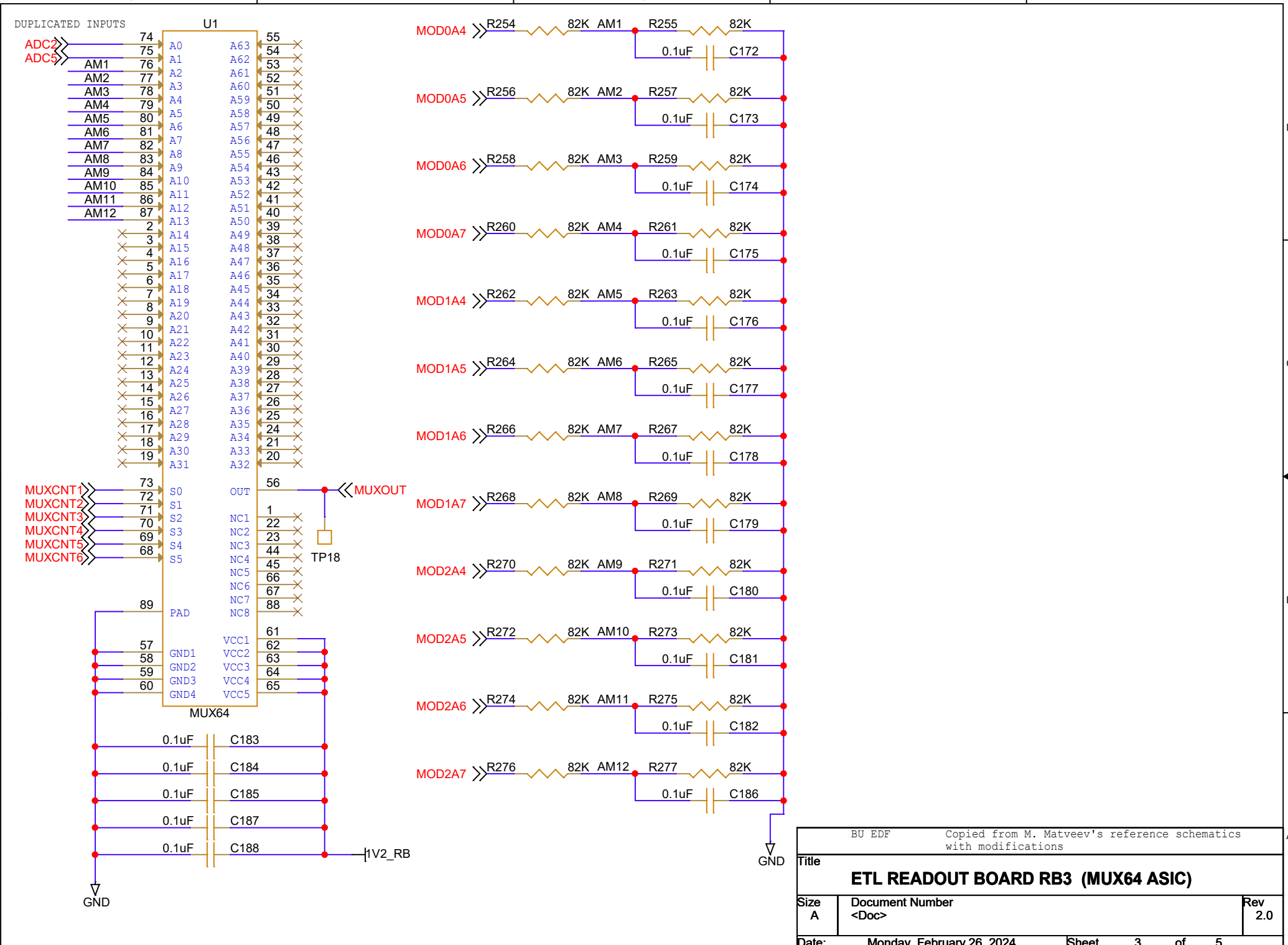

BU EDF		Copied from M. Matveev's reference schematics with modifications	
<b>Title</b>			
<b>ETL READOUT BOARD RB3 (MUX64 ASIC)</b>			
<b>Size</b>	<b>Document Number</b>		<b>Rev</b>
A	<Doc>		2.0
<b>Date:</b>		<b>Monday, February 26, 2024</b>	<b>Sheet 3 of 5</b>

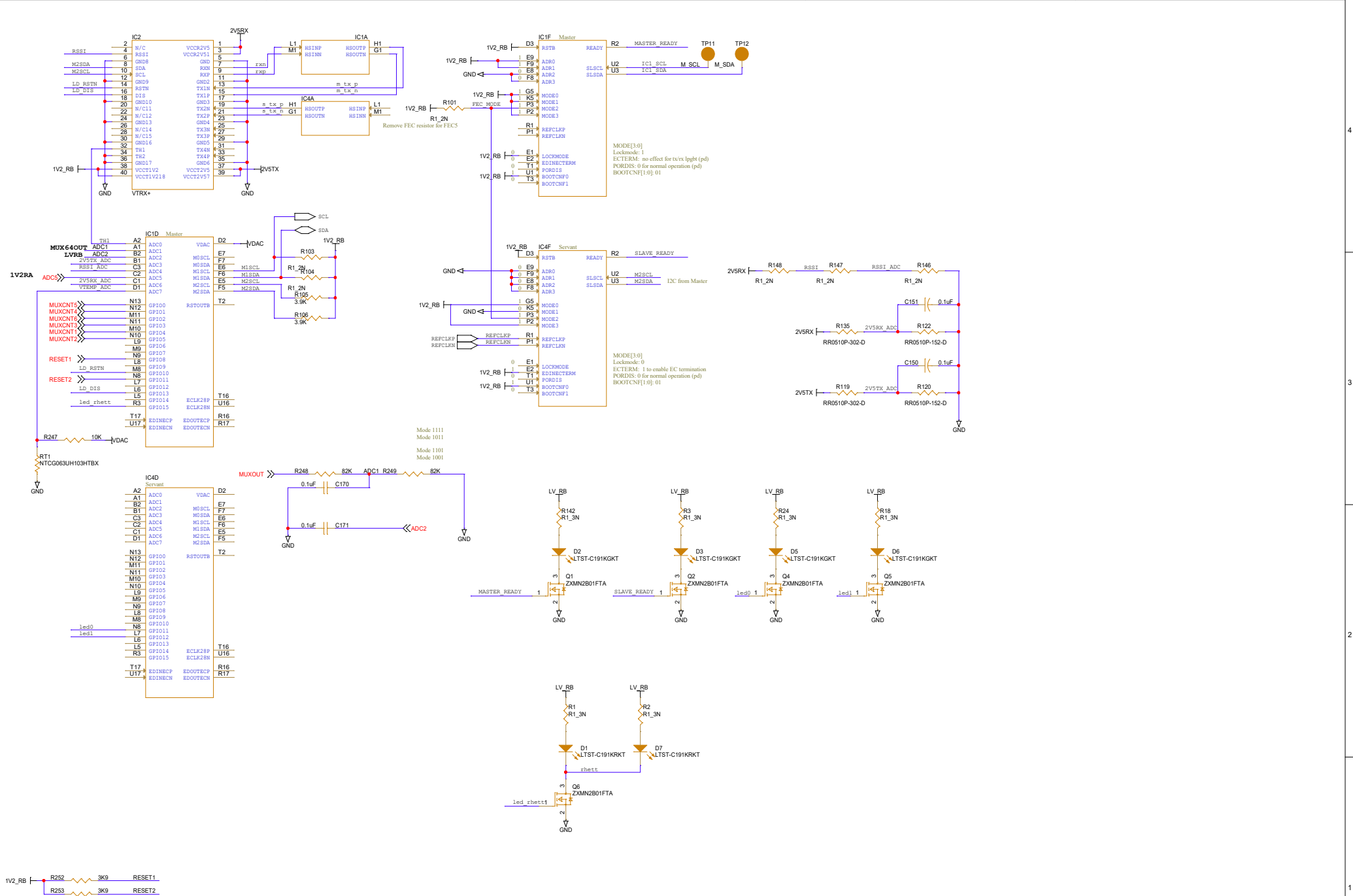

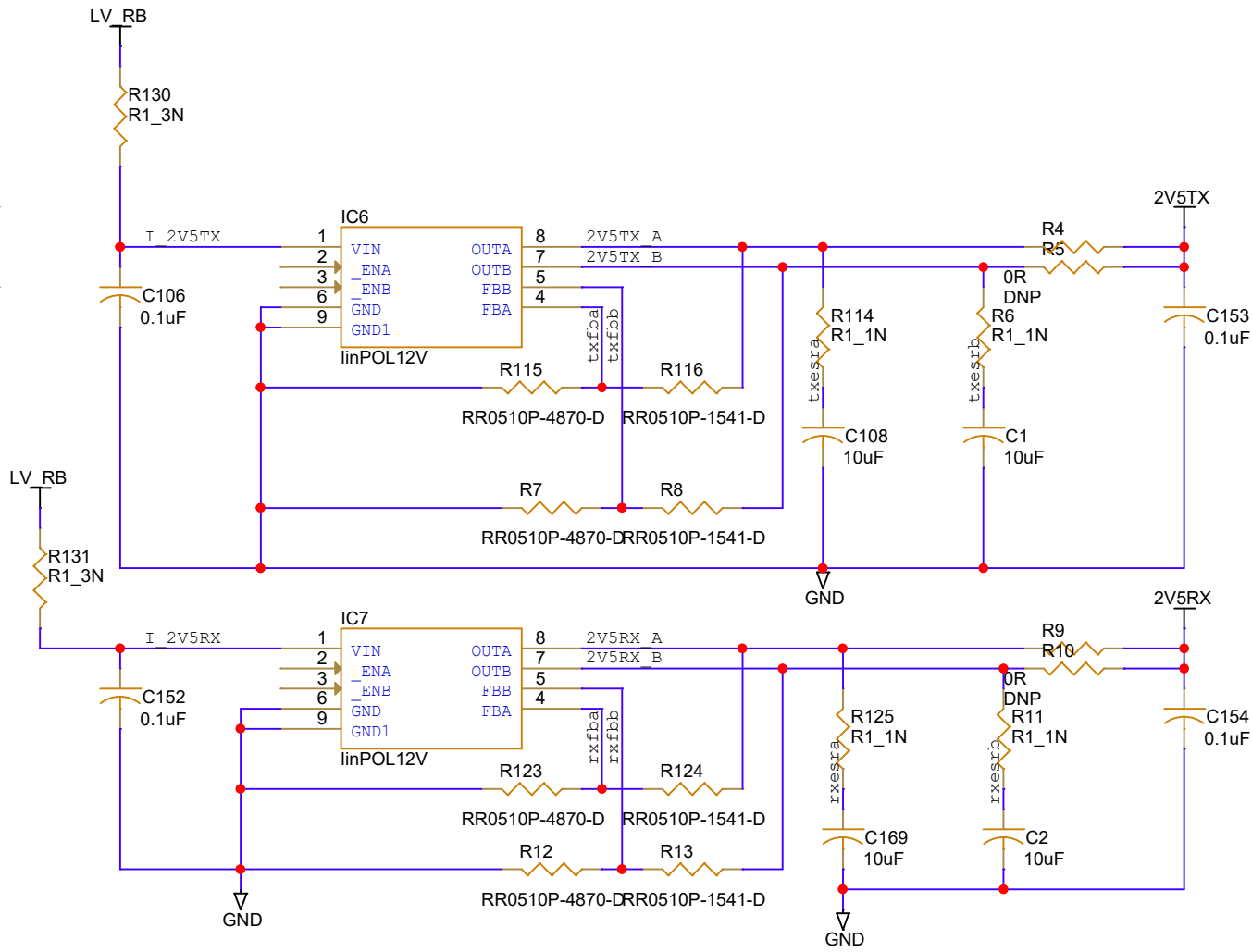
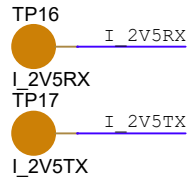

BU EDF		
Title <b>ETL READOUT BOARD RB3 (MUX64 ASIC)</b>		
Size A	Document Number <Doc>	Rev 2.0
Date:	Monday, February 26, 2024	Sheet 3 of 5

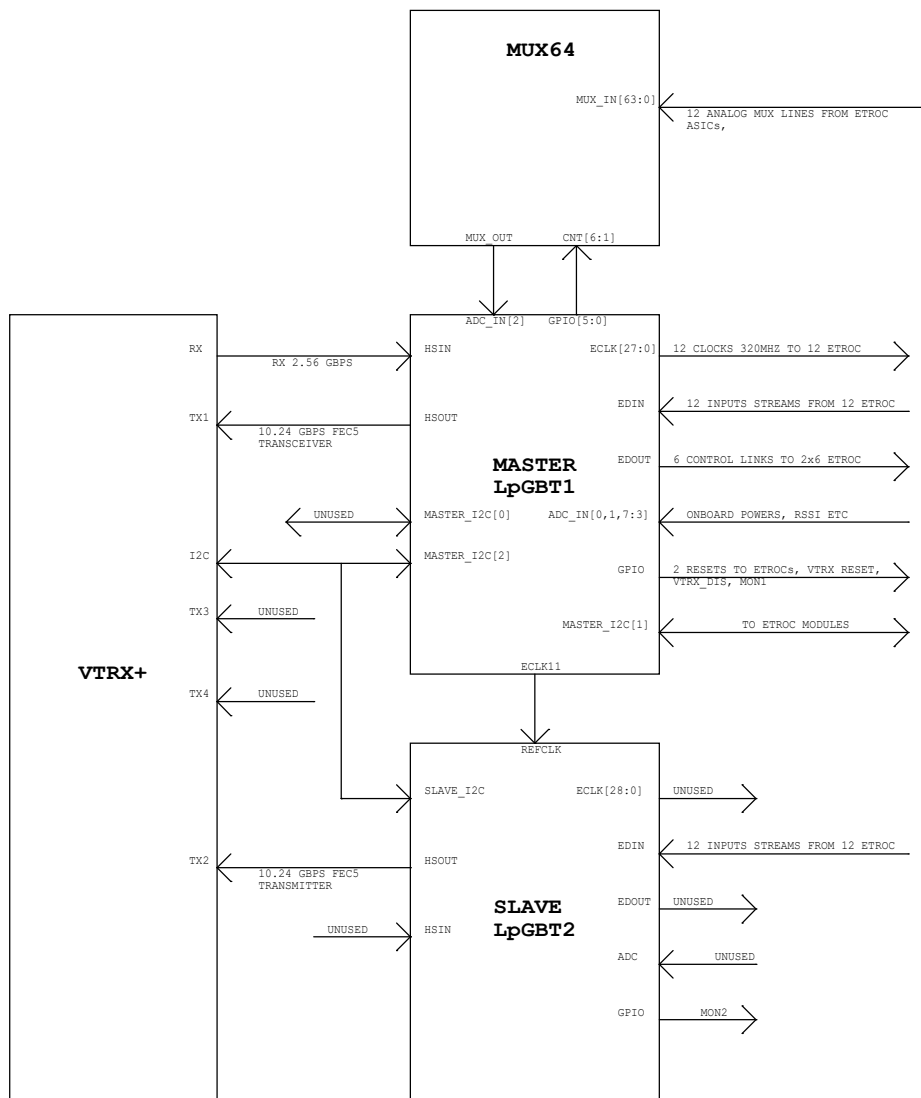

Title			BU EDF This overall block diagram created by M. Matveev
Size			Document Number
B			<Doc>
Date:			Monday, February 26, 2024
Sheet		3	of 5
Rev		2.0	